

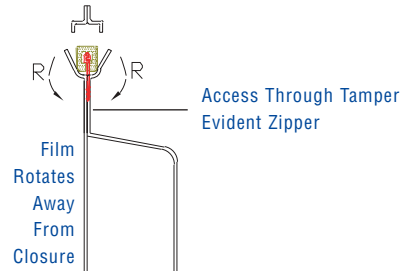

## Model SR-2002 Dual Applicator

FEATURES	MACHINE SPECIFICATIONS	
<ul style="list-style-type: none"> <li>• Creates multiple Slide-Rite segment streams with attached sliders and sonic end stops</li> <li>• Integrates into thermoformed HFFS tray lines</li> <li>• Provides a reclosable slider package with a below the track barrier tamper-evident membrane, eliminating the need for a peel-seal system</li> <li>• Stand alone design is available with CE compliant electrical panel</li> <li>• Hermetically sealed operator panel mounted on adjustable swivel arm</li> <li>• Complete wash-down construction</li> <li>• Compatible with most thermoformed HFFS tray lines and proven on the Multivac platform</li> </ul> 	Production Speed:	60 CPM per segment stream
	Package Widths:	Standard: 6.75 to 11 inches (170 to 280 mm)
	Electrical Requirements:	220 VAC, 3 phase 50/60 Hz single phase 30 amps max.
	Compressed Air Requirements:	Clean & Dry @ 7 SCFM (197 liters/min), 80 PSI (5.4 atm)
	Shipping Weight (Approx.):	2,000 lbs. (910 kg)

PACKAGING DESIGN APPLICATION

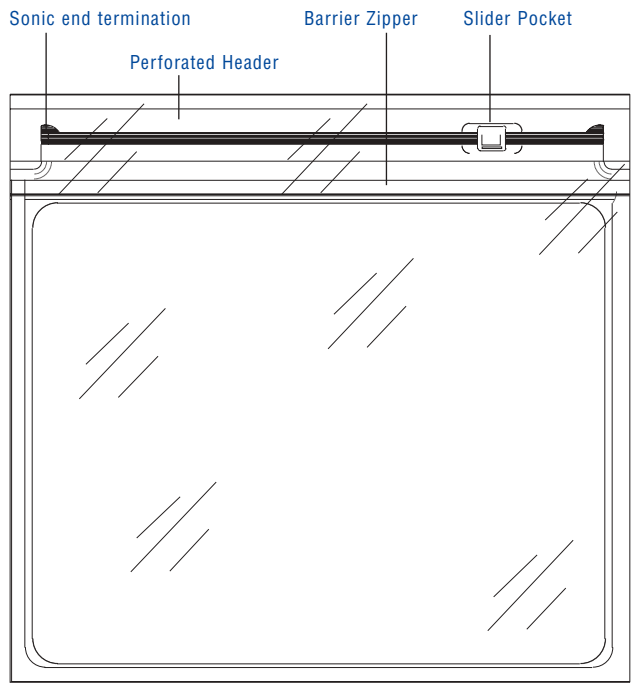

TYPICAL MACHINE FOOTPRINT

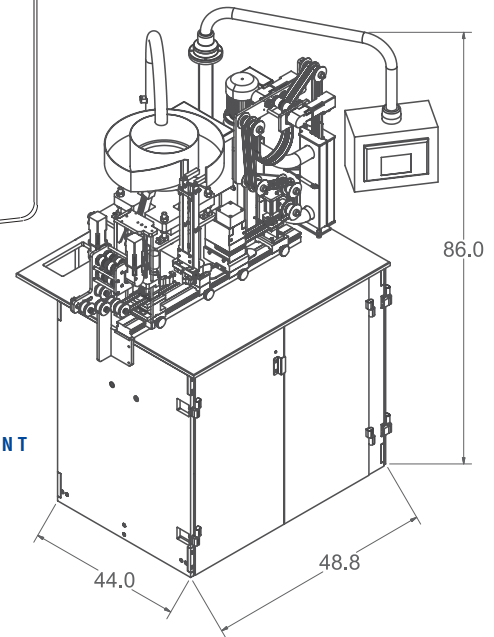

NEEDS	SLIDE-RITE SOLUTIONS
Increased Customer Satisfaction	<ul style="list-style-type: none"> <li>Patented Easy Open, Easy Close slider system</li> <li>Stays closed more securely</li> </ul>
Reclosable System Performance	<ul style="list-style-type: none"> <li>Positive close every time</li> <li>Sonic end stop termination that keeps the slider on the bag</li> <li>Contaminant resistant track options</li> </ul>
Product Integrity and Differentiation	<ul style="list-style-type: none"> <li>“Hooded” configuration provides on-the-shelf visual tamper-evidence</li> <li>Additional below the track tamper-evident membrane provides a hermetic seal and eliminates the need for a peel-seal system</li> <li>Multi-layer co-extruded track provides barrier protection and maintains MAP environment</li> <li>True value-added packaging</li> </ul>
Proven Technology	<ul style="list-style-type: none"> <li>Over 10 years of experience in slider technology</li> <li>Over 40 patents issued</li> <li>Multiple consumer packages commercialized</li> </ul>
Machine Compatibility	<ul style="list-style-type: none"> <li>Compatible with most thermoformed HFFS tray lines</li> <li>Slider Integration technology available as part of OEM machinery or as a retrofit</li> </ul>